

## 5.0 cu. ft. Front Load Washer

- 5.0 cu. ft. Mega Capacity
- TurboWash® 360° Technology
- AI Fabric Sensor / Smart Pairing™
- ezDispense™ Automatic Dispenser
- 25 Cycles / 19 Options
- Allergiene™ Cycle
- ColdWash™ Option
- Direct Drive Motor (10-Year Limited Warranty)
- NeveRust™ Stainless Steel Tub
- LG ThinQ® Technology (Wi-Fi)



### COLOR AVAILABILITY

- WM6700HBA – Black Steel

### CAPACITY & MATCHING DRYERS

Capacity (cu. ft.)	5.0
Matching Electric Dryer	DLEX6700B
Matching Gas Dryer	DLGX6701B

### APPEARANCE

Electronic Controls with LCD Display	Yes
Hard Buttons	No
Touch Buttons	Yes
Dial-A-Cycle™	Yes

### ENERGY & WATER

ENERGY STAR® Certified	Yes
CEE Qualified	Advanced Tier
Integrated Modified Energy Factor (IMEF)	3.1
Integrated Water Factor (IWF)	2.9

### WASH CYCLES

Number of Cycles	25
Wash Cycles	Normal, AI Wash, Bedding, Delicates, Towels, Quick Wash, Heavy Duty, Allergiene™, Perm. Press, Tub Clean, Bright Whites™, Sanitary, Rinse + Spin, Spin Only, Hand/Wool, Active Wear, Swimwear, Kids Wear, Jeans, Dresses, Color Care, Sweat Stains, Small Load, Large Load, X Large Load

### WASH OPTIONS

Number of Options	19
Options	TurboWash®, Steam, Fresh Care, Pre-Wash, Remote Start, Delay Wash, Wi-Fi, Add Item, Extra Rinse, Control Lock, Drum Light, ColdWash, Spin Only, Detergent Level, Softener Level, Signal, Cycle List Edit, Cycle Optimization, Softener Tank Use

### WASH DETAILS

Internal Heater	Yes
Number of Wash / Rinse Temps	5
Wash / Rinse Temps	Extra Hot, Hot, Warm, Cold, Tap Cold
Number of Spin Speeds	5
Spin Speeds	Extra High, High, Medium, Low, No Spin
Max RPM	1,300
Water Levels	Load Sensing
Number of Soil Levels	5
AAFA Certified	Yes

### FABRIC CARE

AI DD™	Yes
Wash Technology	TurboWash® 360
Steam Technology	Yes
Allergiene™ Cycle	Yes
Sanitary Cycle	Yes
ColdWash™ Option	Yes
AI Fabric Sensor	Yes
Soil Level Sensor	Yes

### CONVENIENCE

Vibration Sensing (Cabinet Vibration Sensor)	Yes
TrueBalance™ Anti-Vibration System	Yes
Dispenser Type	ezDispense Cartridge (Detergent, Softener), Main Wash, Bleach (Cup)
Drum Light	Yes
End of Cycle Signal	Yes
LoadSense	Yes
Control Lock	Yes
Auto Suds Removal	Yes
4 Adjustable Leveling Legs	Yes
ADA Compliant	No

## SMART FEATURES

Wi-Fi Enabled	Yes
ThinQ® Technology	Yes
ThinQ Care	Yes
Voice Control	Google Assistant, Amazon Alexa
SmartDiagnosis™	Yes
Remote Start (On / Off)	Yes
Remote Monitoring & Notifications	Yes
Energy Monitoring	Yes
Tub Clean Coach	Yes

## MOTOR AND AGITATOR

Motor Type	Inverter Direct Drive Motor
Axis	Horizontal

## MATERIALS AND FINISHES

NeveRust™ Stainless Steel Drum	Yes
Cabinet / Control Panel / Top Plate	Painted Steel
Door / Rim	Glass / Chrome
Door Cover	Tempered Glass Door

## TECHNICAL SPECS

Electrical Requirements	120V, 60 Hz, 10 Amps
Type	Electric
Power Outlet Location	Within 60" of Either Side
Plug Type	3-Prong (Cord Attached to Unit)
Min. / Max. Water Pressure	20 - 120 psi

## INCLUDED ACCESSORIES

Drain Hose, Non-Skid Pads, Hole Caps, Wrench, Tie Strap, Elbow Bracket (for Securing Drain Hose)

## OPTIONAL ACCESSORIES

Pedestal	WDP6B
Pedestal (W x H x D)	27" x 13 5/8" x 28" (43 7/8" D with Door Open)
ADA-Compliant Pedestal Riser	WDPS2B
ADA-Compliant Pedestal Riser (W x H x D)	27" x 5 1/8" x 27"
LG Sidekick™ Pedestal Washer	WD300CB
LG Sidekick™ Pedestal Washer (W x H x D)	27" x 14 1/8" x 30 3/4" (50 1/2" D with Drawer Open)
Stacking Kit	KSTK4

## DIMENSIONS

Product (W x H x D)	27" x 39" x 33 1/4"
Depth with Door Open	55"
Cutout Dimensions (W x H x D)	29" x 39 1/4" x 37 1/4"
Carton Dimensions (W x H x D)	29 3/4" x 43 1/8" x 33 7/8"
Approx. Weight (Product / Carton)	209.5 lbs. / 222.7 lbs.

## LIMITED WARRANTY

Parts and Labor	1 Year
Direct Drive Motor	10 Years (Parts Only)
Drum	3 Years (Parts Only)

## DIMENSIONS / CLEARANCES

### FLOOR INSTALLATION

To ensure sufficient clearance for water inlet hoses, drain hose and airflow, allow minimum clearances of at least 1 inch (2.5 cm) at the sides and 4 inches (10 cm) behind the washer. Be sure to allow for wall, door, or floor moldings that may increase the required clearances.

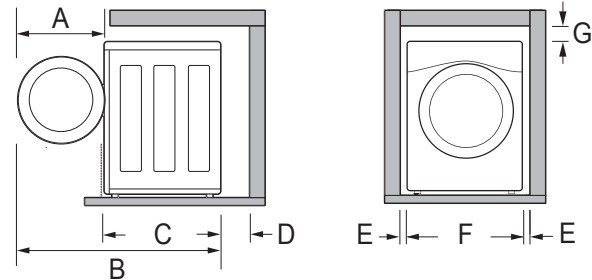

## DIMENSIONS / CLEARANCES

A	24 3/4" (62.6 cm)
B	55" (139.6 cm)
C	33 1/4" (84 cm)
D	4" (10 cm)
E	1" (2.5 cm)
F	27" (70 cm)
G	1/4" (0.5 cm)

### STACKING OR PEDESTAL INSTALLATION

The washer can be stacked under a dryer or on top of a pedestal or pedestal washer.

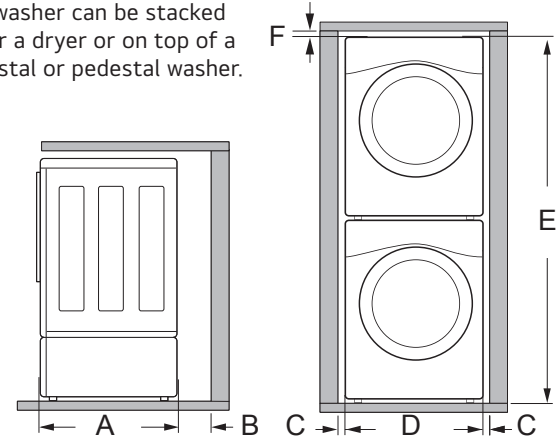

## DIMENSIONS / CLEARANCES

A	33 1/4" (84 cm)
B	4" (10 cm)
C	1" (0.5 cm)
D	27" (70 cm)
E	77 1/2" (196.8 cm)
F	1/4" (0.5 cm)

ASTHMA & ALLERGY FRIENDLY Mark is a Registered Trade Mark of the ASTHMA AND ALLERGY FOUNDATION OF AMERICA and ALLERGY STANDARDS LTD.